

Rail Tonneau Systems *by LeBra*

Installation Instructions

TM 3B LC

**TOP MOUNT
SYSTEM**

Thank you for purchasing a Top Mount Rail Tonneau System. Global Accessories, Inc. has constructed this tonneau cover using the finest quality materials and craftsmanship available. Given proper care, your tonneau cover will give you years of service.

NO DRILLING IN THE TRUCK BED IS REQUIRED

INSTALLATION TIPS

1. For additional ease of installation, install your rail tonneau in temperatures above 70° F (21° C).
2. Please read all instructions before installing the cover. You should allow about 30 minutes to complete the installation.
3. Wash truck to ensure that no dirt or abrasive materials are caught between your truck's finish and the tonneau rail frame.
4. It is normal for your tonneau cover to contract and wrinkle in the shipping carton. The cover will expand and the wrinkles will disappear within a few days after installation.
5. If you encounter any problems during the installation, please contact our Customer Service Department, Monday - Friday, 7AM - 6PM (MST) at 1-800-950-9502.

UNPACKING THE CONTENTS OF THE SHIPPING PACKAGE

Remove all parts from the shipping container. Check each part included against the following Parts List:

PARTS LIST

- | | |
|----------------------------------|------------------|
| 1 - Rail Assembly - Front | 6 - Clamp |
| 1 - Rail Assembly - Rear | 3 - Bow Assembly |
| 1 - Rail Assembly - Side (Right) | |
| 1 - Rail Assembly - Side (Left) | |

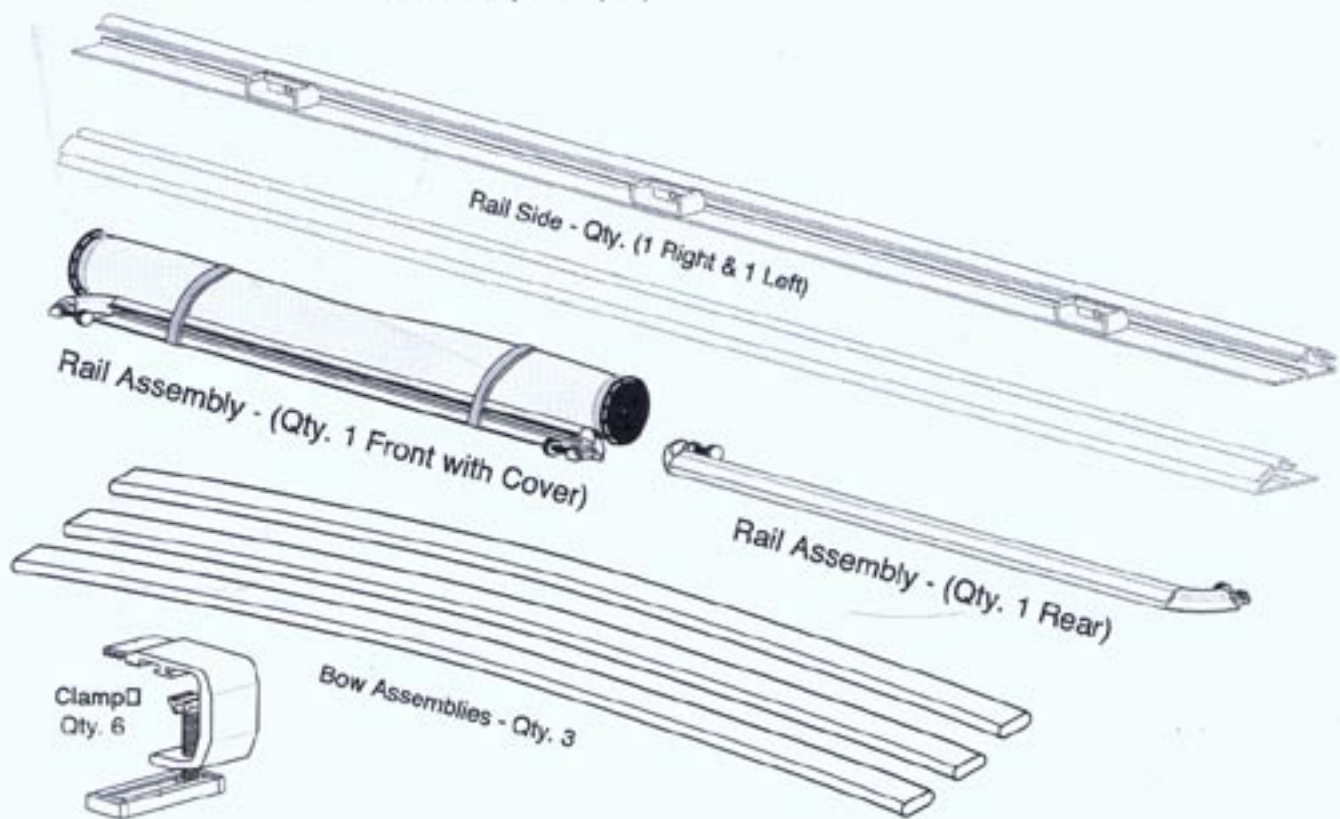

FRAME RAIL AND BOW ASSEMBLY

STEP 1

Locate the Left and Right side rails. Remove paper backing, set the side rails onto the top of the truck box (see Figure 1).

Remove paper backing, set the Front Rail (with cover attached) onto truck and fasten corners by inserting into side rail ends and tightening the thumbscrews (make sure Long ends of roll up straps are to the inside of the truck box). Then, install the rear rail the same way (see Figure 1).

FIGURE 1

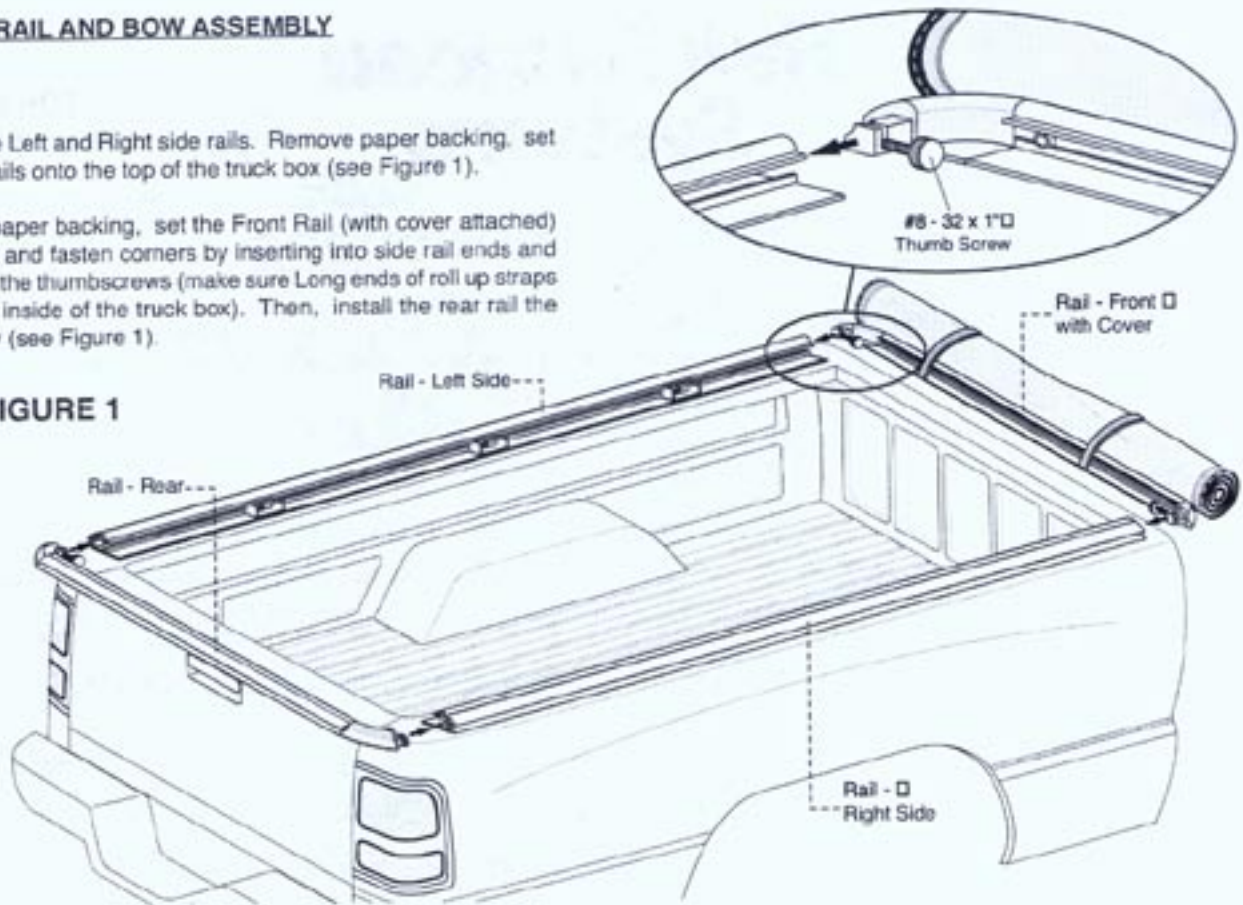

STEP 2

Align the inside edge of the Front Rail with the inside edge of the truck bed (Note: If you have Part # 93-84115/112, align outside edge with outside edge of cargo box) and center the assembly from side to side (see Figure 2). The clamps secure the rail system to the truck bed. The clamps secure the rail system to the cargo box. Mount the clamps to the side rails as shown in Detail A. Position a clamp approximately 12" from each front corner (see Figure 2) and tighten using the slide handle. Do the same at the rear of the frame. Place the remaining clamps in between the previously placed clamps.

FIGURE 2

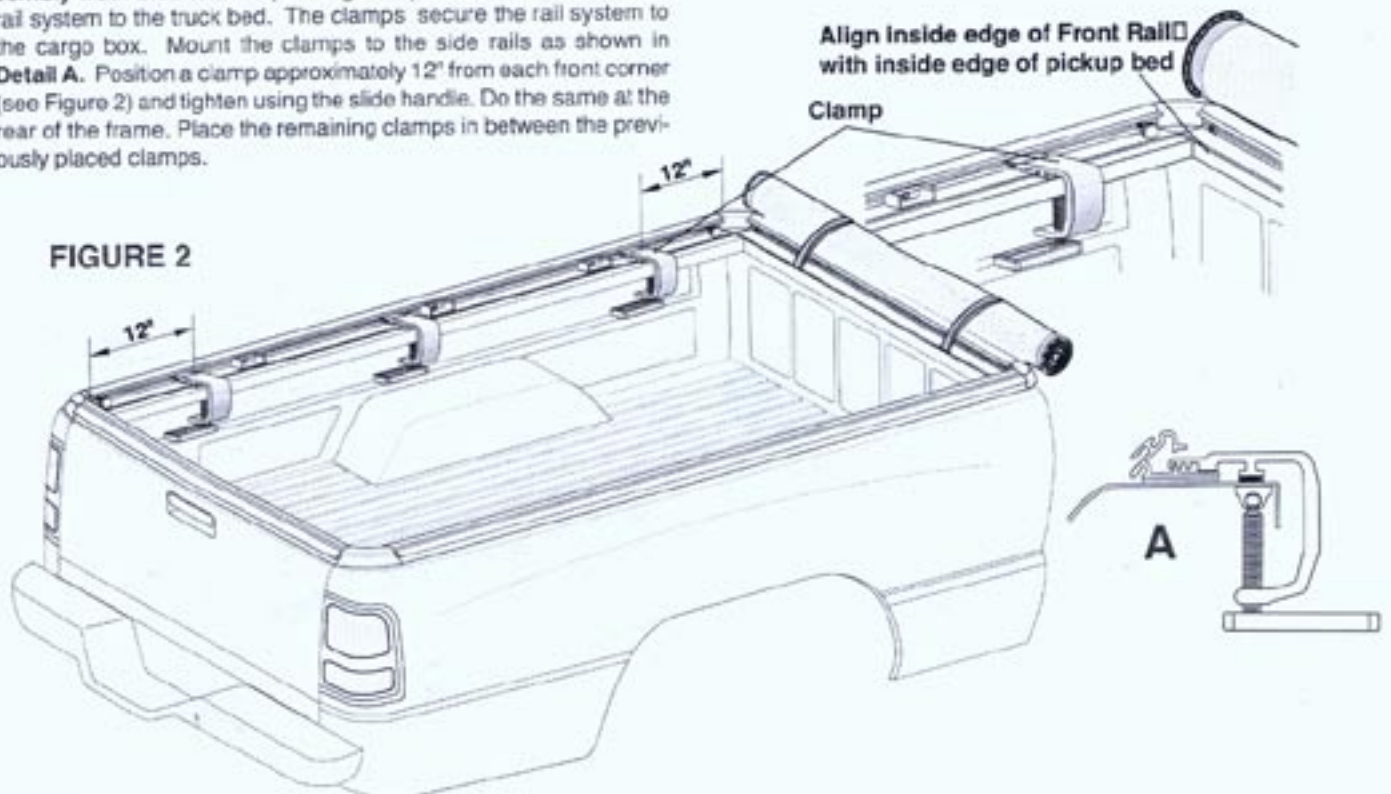

Notched
for clamps.



SUGGESTIONS FOR MOUNTING TOP MOUNT RAIL TONNEAU COVER WITH A BEDLINER

These are only suggestions. There are many different types of bedliners on the market and no simple guidelines can be established. **Global Acc. is not responsible for modifications made to bedliner resulting from Rail Tonneau installation.**

Under The Rail Bedliner:

Front: In some cases it may be necessary to trim the front edge off the bedliner. If the front edge of the liner rises up above the truckbed and interferes with the weather stripping on the front rail, the liner must be trimmed.

Affix a "U-channel" aluminum extrusion (not included) to prevent weakening or warping of bedliner after trimming.

Over The Rail Bedliner:

Remove T-handles from the clamp (top right illustration). In order to do this, remove plastic end cap on either side of T-handle.

Using clamps as a guide, mark each clamp location and notch out the bedliner (see bottom right illustration). Reinsert clamps.

Rail system is now ready for a typical installation. The only exception is that now the clamps will need to be tightened using a wrench.



Removal of T Handle



Notched for Rail Clamps.

FRAME RAIL AND BOW ASSEMBLY (continued)

STEP 3

Locate the bows. Place one end of the bow (marked FRONT on its underside) into one of the front bow mounts, then snap the other end into place (see Figure 3). Do the same with the MIDDLE and REAR bows.

Note: Only trucks with tapered cargo boxes will have Bows marked FRONT, MIDDLE and REAR.

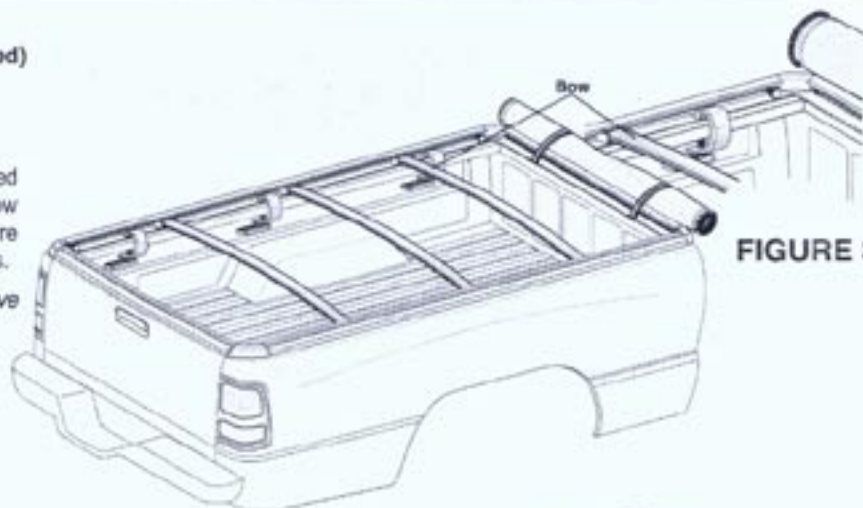

FIGURE 3

COVER ASSEMBLY

The plastic strips along the three sides of the vinyl cover fit into the grooves in the rail assembly.

STEP 1

Pull the cover over the bows to the rear of the truck. Center the fabric LeBra® tag above the tailgate latch (see Figure 4) and begin inserting the plastic strip into the groove working out to each rear corner. Use one hand to insert and the other to guide the plastic into the groove.

STEP 2

Starting at either the front or rear corner, insert the plastic strip into the groove and work to the opposite corner (see Figure 4). Do the same for the opposite side.

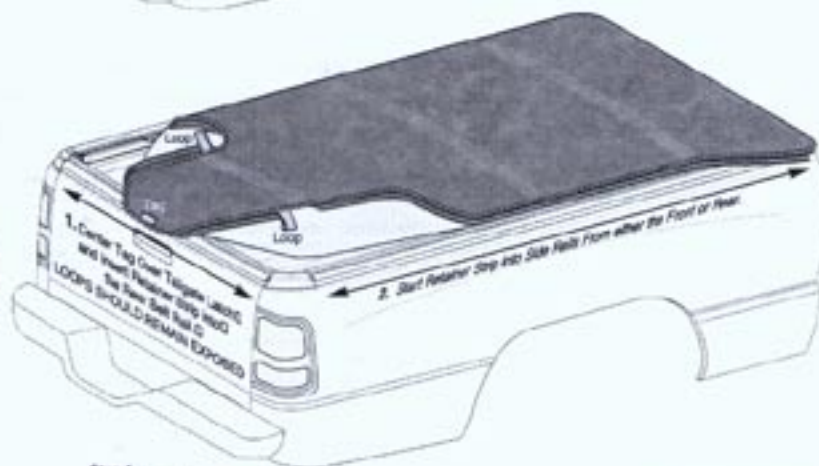

FIGURE 4

The installation is now complete.

COVER REMOVAL

To remove cover, use the loops (either Right or Left rear corner) and ease the plastic strip out of the rail by pulling **DOWN** and **OUT** (see Figure 5). Then peel the plastic strip out of the remainder of the rear rail. **Pull DOWN and OUT on the vinyl fabric to remove the plastic strips from the sides of the rail assembly.**

To fasten cover, repeat step 2 of the COVER ASSEMBLY.

FIGURE 5

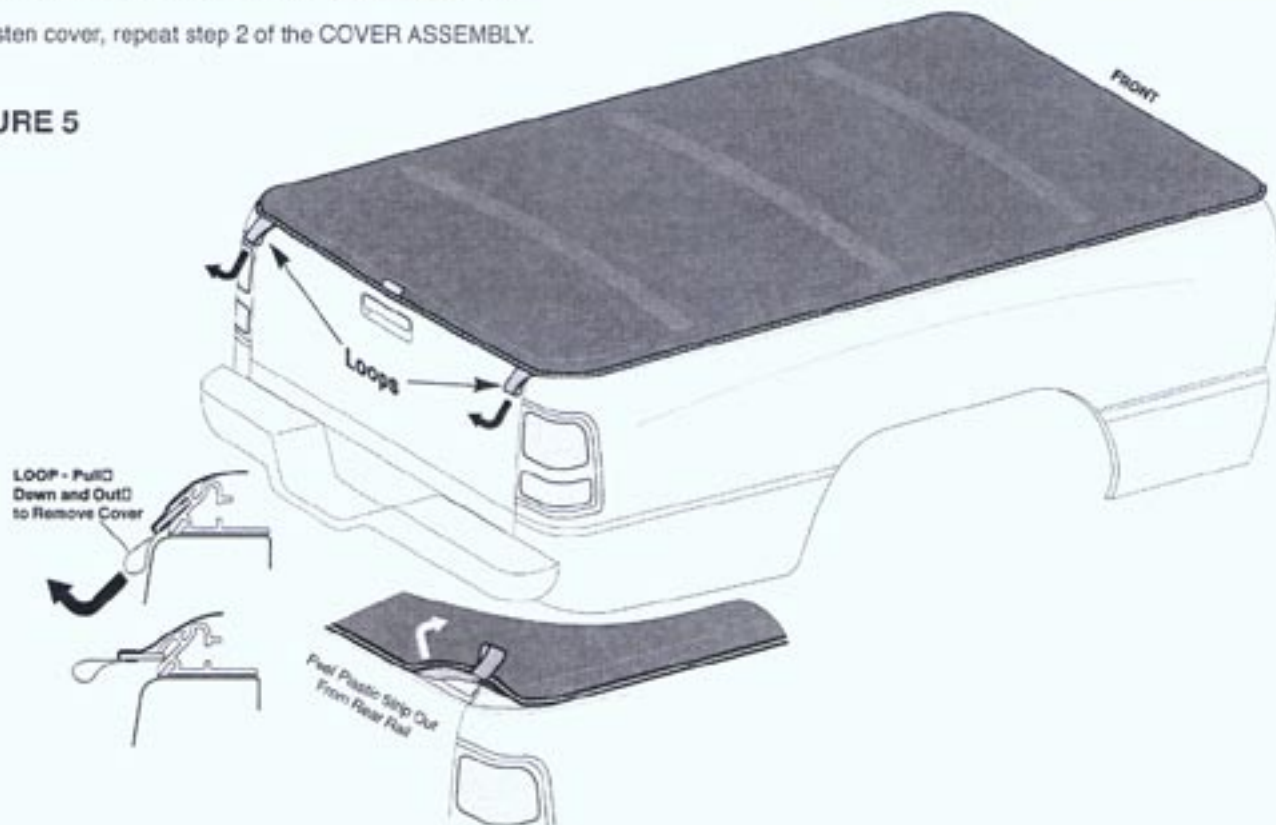

Note: If you encounter any problems during the installation, please contact our Customer Service Department, Monday through Friday, 7:00 AM to 6:00 PM MST at 1-800-950-9502.

CARE INSTRUCTIONS

- Wash your tonneau cover with warm water and mild soap. **DO NOT USE OIL BASED PROTECTANTS OR SILICONE BASED PRODUCTS.**
- Tonneau cover must be secured at all points when vehicle is moving. A tonneau cover that is unsecured will flap, resulting in damage to the vinyl fabric.
- Do not overload bed of truck. Stress on tonneau cover fabric could result in damage.

**For Replacement Parts, Please See Your Local Retailer
Where You Purchased Your Rail Tonneau**

LIMITED WARRANTY

We warrant our product to be free from defects in material or workmanship, for the term specified below, provided there has been normal use and proper maintenance. This warranty applies to the original purchaser only. All remedies under this warranty are limited to the repair or replacement of any item or items found by the factory to be defective within the time period specified.

If you have a warranty claim, first you must call our factory at the number below for instructions. You must retain proof of purchase and submit a copy with any items returned for warranty work. We will return the repaired or replaced items to you freight prepaid. Damage to our products caused by accidents, fire, vandalism, negligence, misuse, Acts of God, or by defective parts not manufactured by us, are not covered under this warranty.

THE TERMS OF OUR WARRANTY ARE AS FOLLOWS: A. RAIL, TONNEAU SYSTEM HARDWARE KIT (CLAMPS, RAILS, BOWS) FULL LIFETIME OF OWNERSHIP BY THE ORIGINAL PURCHASER. B. TONNEAU COVER FABRIC IS WARRANTED FOR ONE YEAR FROM THE DATE OF PURCHASE.

ANY IMPLIED WARRANTIES OF MERCHANTABILITY AND/OR FITNESS FOR A PARTICULAR PURPOSE CREATED HEREBY ARE LIMITED IN DURATION AS THE EXPRESS WRITTEN WARRANTY. OUR COMPANY SHALL NOT BE LIABLE FOR ANY INCIDENTAL OR CONSEQUENTIAL DAMAGE, INCLUDING, WITHOUT LIMITATION, DAMAGES RESULTING FROM THE USE OF THE PRODUCT ON REPAINTED SURFACES (NON-FACTORY ORIGINAL PAINT) AND FADING AND PAINT COLORATION DIFFERENCES RESULTING FROM THE PRODUCT'S SHIELDING PORTIONS OF SURFACES FROM EXPOSURE TO THE SUN AND ELEMENTS WHILE OTHER ADJACENT SURFACES REMAIN COMPLETELY EXPOSED. THIS WARRANTY IS LIMITED TO FUNCTIONALITY OF PRODUCT, NOT COSMETIC RELATED ISSUES.

Some states do not allow limitations on how long an implied warranty lasts, or the exclusion or limitation of incidental or consequential damages, so the above limitations or exclusions may not apply to you. This warranty gives you specific legal rights, and you may also have other rights which vary by state to state. For further information or request for warranty work, please contact:

GLOBAL
ACCESSORIES, INC.

80 West 900 South
Logan, UT 84323
Customer Service (800) 950-9502

Rail Tonneau Systems by LeBra

TMI
TOP MOUNT
SYSTEM

Additional Points to Emphasize When Installing & Operating Your LeBra® Rail Tonneau System

Installation Tip:

For additional ease of installation, install your rail tonneau in temperatures above 70° F (21° C).

A. Corner Protection

After the frame rail has been assembled on a level surface, use two people to lay frame rail assembly on top of truck bed to avoid extreme pressure on corners.

For ease of installation, the cover should be rolled up when inserting the front strip into the channel.

B. Cover Assembly

Before cover assembly, make sure the inside edge of the front rail is aligned with the inside edge of the truck bed and rail assembly is centered side to side.

For cover assembly, follow the steps in the order indicated in the illustration below:

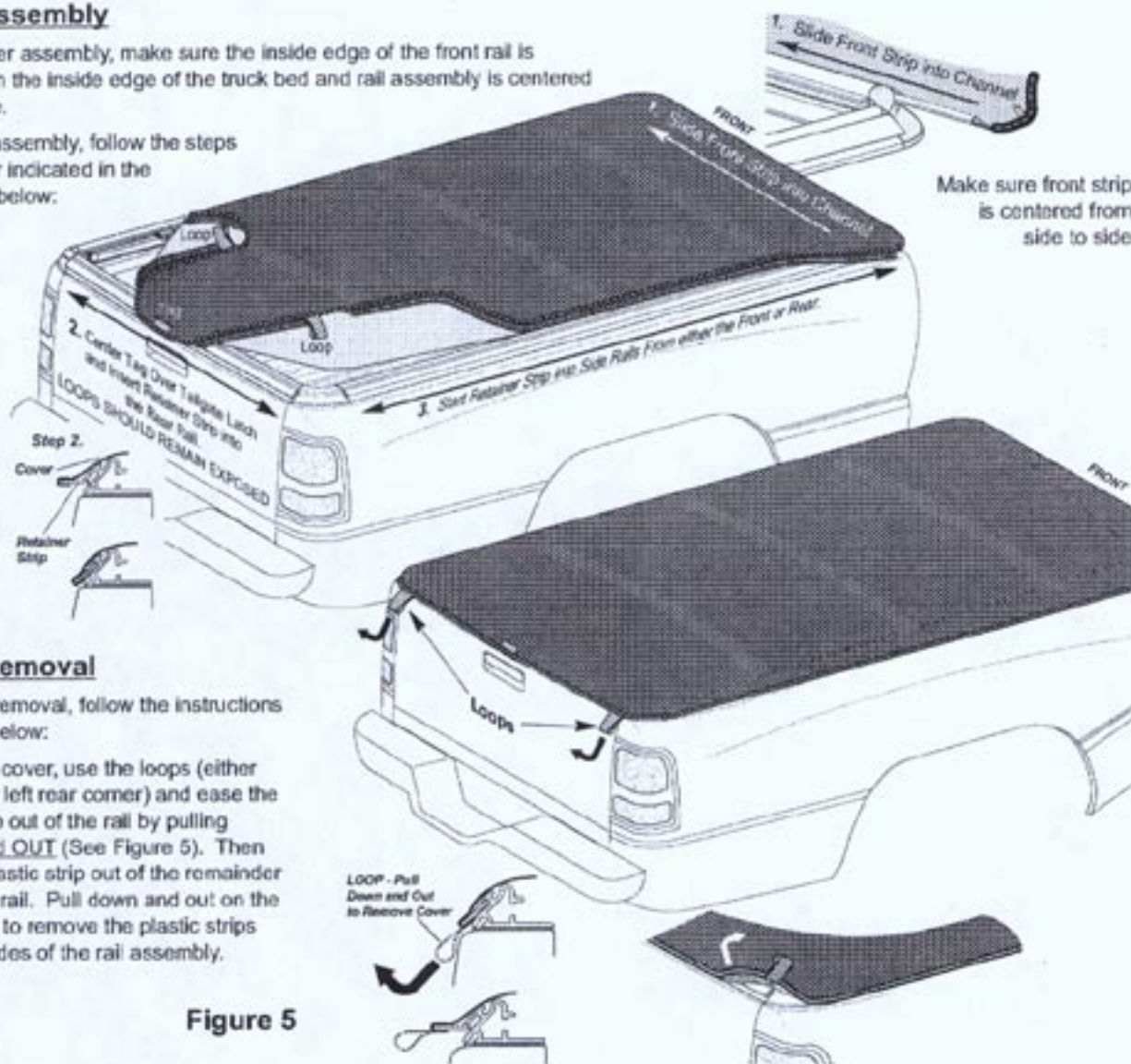

C. Cover Removal

For cover removal, follow the instructions indicated below:

To remove cover, use the loops (either the right or left rear corner) and ease the plastic strip out of the rail by pulling **DOWN and OUT** (See Figure 5). Then peel the plastic strip out of the remainder of the rear rail. Pull down and out on the vinyl fabric to remove the plastic strips from the sides of the rail assembly.

Figure 5