

ADJUSTMENTS

ADJUSTMENT - BANDS

FRONT BAND

The front (kickdown) band adjusting screw (2) is located on the left side of the transmission case above the manual valve and throttle valve levers.

1. Raise vehicle.
2. Loosen band adjusting screw locknut. Then back locknut (1) off 3-5 turns. Be sure adjusting screw turns freely in case. Apply lubricant to screw threads if necessary.
3. Tighten band adjusting screw to 8 N·m (72 in. lbs.) torque with an appropriate Torx™ socket.

CAUTION: If Adapter C-3705 is needed to reach the adjusting screw, tighten the screw to only 5 N·m (47-50 in. lbs.) torque.

4. Back off front band adjusting screw 1-3/4 turns, for diesel vehicles, or 1-1/2 turns, for V-10 vehicles.
5. Hold adjuster screw in position and tighten locknut to 41 N·m (30 ft. lbs.) torque.
6. Lower vehicle.

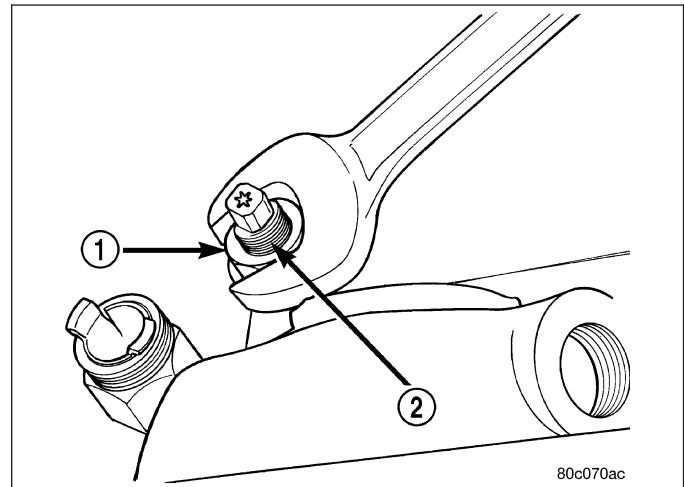

REAR BAND

The transmission oil pan must be removed for access to the rear band adjusting screw (1).

1. Raise vehicle.
2. Remove transmission oil pan and drain fluid.
3. Loosen band adjusting screw locknut 5-6 turns. Be sure adjusting screw turns freely in lever.
4. Tighten adjusting screw to 8 N·m (72 in. lbs.) torque.
5. Back off adjusting screw 3 turns.
6. Hold adjusting screw in place and tighten locknut to 34 N·m (25 ft. lbs.) torque.
7. Position new gasket on oil pan and install pan on transmission. Tighten pan bolts to 17 N·m (13 ft. lbs.) torque.
8. Lower vehicle and refill transmission with Mopar® ATF +4, Automatic Transmission fluid.

